



Engine

Make/Type Model	Yanmar 3TNV76 water cooled 3 cyl. diesel engine
max. engine output	17,9 kW (24,3 HP)
Performance to ISO	13,2 kW (17,9 HP)
Engine displacement	1116 cm ³
Travel speed	2200 min ⁻¹
Battery	12V/45 Ah
Fuel tank capacity	24 l



Hydraulic system

Pump	Double variable capacity pump + 2 gear pumps
Pump capacity	23,9 + 23,9 + 19,1 + 6,5 l/min
Operating pressure for working and driving hydraulics	200 bar
Operating pressure for slewing gear	150 bar
Hydraulic oil cooler	standard
Hydraulic tank capacity	21 l



Undercarriage and slewing system

Travel speed - dual	2 km/h and 4,1 km/h
Gradeability	30°/58%
Crawler width	250 mm
N° track rollers per side	4
Ground clearance	180 mm
Ground pressure	0,27 kg/cm ²
Superstructure slewing speed	10 min ⁻¹



Dozer Blade

Width	990 mm
Height	260 mm
max. lift above ground	245 mm
max. lift below ground	238 mm



Lifting power index

A \ B	max.		3,0 m		2,5 m		2,0 m		1,5 m	
	along	across	along	across	along	across	along	across	along	across
3,0 m	415*	415*	-	-	400*	400*	-	-	-	-
2,0 m	395*	330	390*	380	400*	400*	-	-	-	-
1,0 m	405*	285	455*	370	550*	475	755*	650	1105*	760
0,0 m	425*	290	510*	340	665*	445	920*	615	1360*	700
-1,0 m	440*	360	-	-	580*	445	795*	610	1145*	680
-1,5 m	435*	435*	-	-	-	-	580*	580*	830*	710*

A = projection from turnstile centre, B = load fixing height from ground level
 *The lifting power is hydraulically limited.
 The data (kg) refer to the machine without digging equipment and are in compliance with ISO 10567.
 Overall length with dozer blade supported.
 Neither 75% of the static tilting load nor 87% of the hydraulic lifting power are exceeded.



Noise level

Noise level (L _{WA}) (to 2000/14/EG)	93 dB(A)
Noise level (L _{PA}) (to ISO 6394)	75 dB(A)



General specifications

Transport weight with cab/canopy 1940/1850 kg

Dimensions

a	Height	2375 mm
b	Width	990 mm
	Transport length	3990 mm
d	max. digging depth	2500 mm
d*	max. digging depth (long dipperstick)	2639 mm
e	max. vertical digging depth	1670 mm
e*	max. vertical digging depth (long dipperstick)	1855 mm
f	max. digging height	3860 mm
f*	max. digging height (long dipperstick)	3982 mm
g	max. dumping height	2760 mm
g*	max. dumping height (long dipperstick)	2885 mm
h	max. digging radius	4090 mm
h*	max. digging radius (long dipperstick)	4273 mm
j	max. reach on the ground	4000 mm
j*	max. reach on the ground (long dipperstick)	4185 mm
k	Tail slewing radius	1160 mm
	max. boom offset to centre of bucket right side	508 mm
	max. boom offset to centre of bucket left side	331 mm
n	max. height above ground	245 mm
o	max. depth below ground	238 mm
p	Track length	1710 mm
q	max. swing angle to the right	45°
r	max. swing angle to the left	80°
s	min. boom radius	1575 mm
t	Crawler width	250 mm

Hydraulic telescopic undercarriage 990 to 1300 mm

max. arm crowd force	12,2 kN
max. bucket digging force	18,8 kN

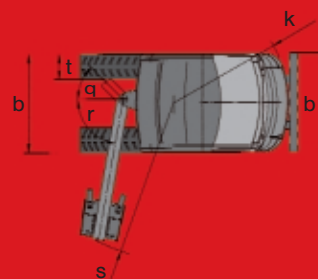
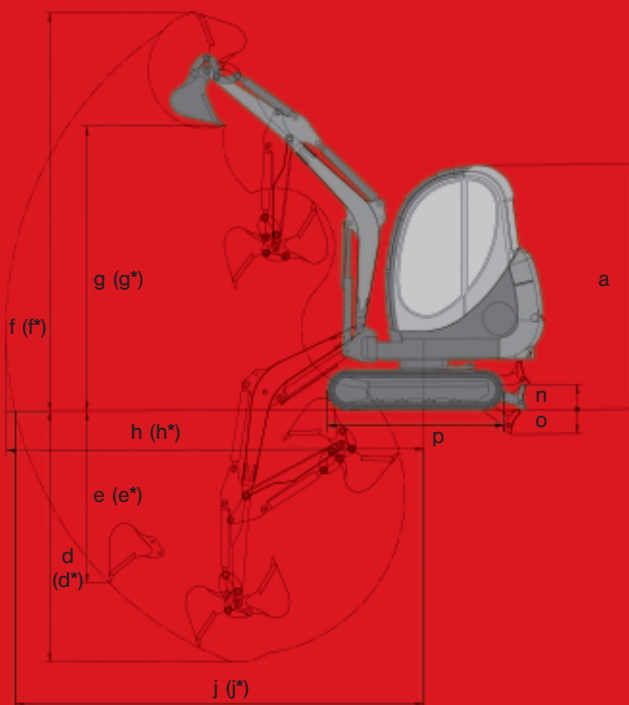

Basic Machine

General

- Rubber track 250 mm
- Dozer blade
- Working light mounted to the boom
- Tool kit incl. grease gun and operator manual

Engine

- Water-cooled YANMAR diesel engine

Cabin

- Canopy: Adjustable and resilient comfort seat with imitation leather cover and safety belt, canopy complies with FOPS-, TOPS- and ROPS-regulations

Hydraulic

- Hydraulic telescopic undercarriage from 990 mm to 1300 mm, with dozer blade extensions
- Summation regulation
- Hydraulic oil cooler
- Hydraulic pilot control via joystick
- Valve control according to ISO, DIN, SAE, PCSA and EURO
- Auxiliary hydraulic connection for two directions of motion, mounted on dipperstick (1050 mm)
- Dual travel speed
- Hydraulically dampened drive pedals and levers

Neuson Baumaschinen GmbH

Haidfeldstraße 37
A-4060 Linz-Leonding

Tel. +43 (0)732 90 590-0
Fax +43 (0)732 90 590-200

e-Mail verkauf@neuson.com
www.neusonkramer.com

Kramer-Werke GmbH

Nußdorfer Straße 50
D-88662 Überlingen

Tel. +49 (0)7551 802-0
Fax +49 (0)7551 802-260

e-Mail info@kramer.de
www.neusonkramer.com

Neuson Ltd.

Crown Business Park
Dukestown, Tredegar
Gwent NP22 4EF
United Kingdom

Tel. +44 (0)1495 72 30 83
Fax +44 (0)1495 71 39 41

e-Mail uksales@neuson.com
www.neusonkramer.com

Options

1903

Cabin

- Standard cab (Safety cabin, cabin heating, split front window, top swings back, bottom lifts out, windscreen wiper and washing system, 1 cabin door, covered cab interior, the cabin complies with FOPS-, TOPS- and ROPS-regulations)
- Cab with 2 doors
- Canopy with back window
- Extension of the backrest
- Radio (Radio set incl. aerial and speakers)
- Rain roof

Hydraulic

- Biological oil Panolin
- BP-Biohyd SE46
- Flat faced couplers
- Proportional control (for auxiliary hydraulic)
- Overload system Germany (Load holding valve boom)
- Overload system France (Load holding valve boom and dipperstick)
- Additional piping for grabble

Painting

- Special paint 1 RAL (Colour for red parts only)
- Special paint 1 no RAL (Colour for red parts only)
- Special paint cabin RAL (RAL colours only)

Miscellaneous

- Cab lighting front
- Cab lighting front and rear
- Anti theft device
- Flashing beacon
- Long dipperstick (+200 mm)
- Dozerblade long
- Security 24 (1500 h) (Warranty extension to 24 months or 1500 operation hours)
- Security 24 (2000 h) (Warranty extension to 24 months or 2000 operation hours)



neuson®