



Engine

Make/Type Model	Yanmar 3TNV88 water cooled 3 cylinder diesel engine (97/68/EC)
max. engine output	27,1 kW (36,8 HP)
Performance to ISO	19,2 kW (26,1 HP)
Engine displacement	1642 cm ³
Travel speed	2200 min ⁻¹
Battery	12V/71Ah
Fuel tank capacity	41 l



Hydraulic system

Pump	Double variable capacity pump + gear pump
Pump capacity	28,5 + 28,5 + 19 l/min
Operating pressure for working and driving hydraulics	240 bar
Operating pressure for slewing gear	200 bar
Hydraulic oil cooler	Standard
Hydraulic tank capacity	27 l



Undercarriage and slewing system

Travel speed - dual	2,3 km/h and 4,4 km/h
Gradeability	30°/58%
Crawler width	250 mm
N° track rollers per side	3
Ground clearance	270 mm
Ground pressure	0,33 kg/cm ²
Superstructure slewing speed	9 min ⁻¹



Dozer Blade

Width	1370 mm
Height	340 mm
max. lift above ground	390 mm
max. lift below ground	415 mm



Lifting power index

A \ B	max.		3,5 m		3,0 m		2,5 m		2,0 m	
	along	across	along	across	along	across	along	across	along	across
3,0 m	415*	415*	-	-	400*	400*	-	-	-	-
2,0 m	410*	350	410*	380	420*	420*	460*	460*	-	-
1,0 m	425*	310	460*	365	540*	460	670*	595	1000*	815
0,0 m	450*	315	505*	355	635*	440	835*	560	1210*	770
-1,0 m	475*	380	-	-	580*	435	790*	560	1030*	775
-2,0 m	445*	445*	-	-	-	-	-	-	435*	435*

A = projection from turnstile centre, B = load fixing height from ground level
 *The lifting power is hydraulically limited.
 The data (kg) refer to the machine without digging equipment and are in compliance with ISO 10567.
 Overall length with dozer blade supported.
 Neither 75% of the static tilting load nor 87% of the hydraulic lifting power are exceeded.



Noise level

Noise level (L _{WA}) (to 2000/14/EG)	94 dB(A)
Noise level (L _{PA}) (to ISO 6394)	74 dB(A)



General specifications

Transport weight with cab/canopy 2620/2525 kg

Dimensions

a	Height	2370 mm
b	Width	1370 mm
	Transport length (boom down)	4410 mm
d	max. digging depth	2620 mm
d*	max. digging depth (long dipperstick)	2825 mm
e	max. vertical digging depth	1810 mm
e*	max. vertical digging depth (long dipperstick)	2000 mm
f	max. digging height	4125 mm
f*	max. digging height (long dipperstick)	4250 mm
g	max. dumping height	2925 mm
g*	max. dumping height (long dipperstick)	3080 mm
h	max. digging radius	4515 mm
h*	max. digging radius (long dipperstick)	4693 mm
j	max. reach on the ground	4410 mm
j*	max. reach on the ground (long dipperstick)	4602 mm
k	Tail slewing radius	1240 mm
	max. boom offset to centre of bucket right side	653 mm
	max. boom offset to centre of bucket left side	393 mm
n	max. lift above ground	390 mm
o	max. lift below ground	415 mm
p	Track length	1840 mm
q	max. swing angle to the right	45 °
r	max. swing angle to the left	80 °
s	min. boom radius	1360 mm
t	Crawler width	250 mm

max. arm crowd force 13 kN
 max. bucket digging force 20 kN

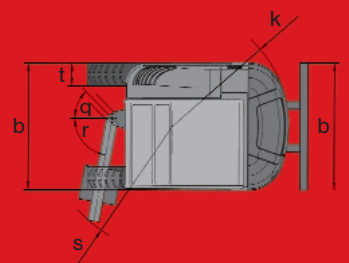
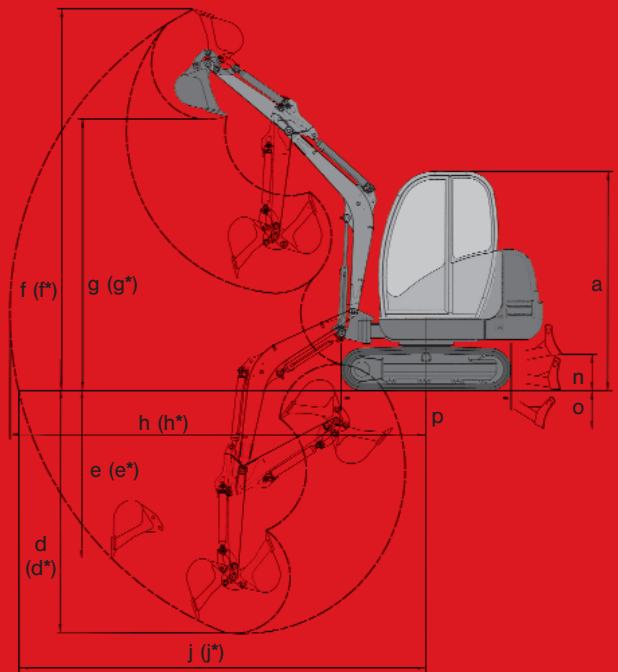

Basic Machine

General

- Rubber track 250 mm
- Dozer blade
- Working light mounted to the boom
- Tool kit incl. grease gun and operator manual

Engine

- Water-cooled YANMAR diesel engine

Cabin

- Canopy: Adjustable and resilient comfort seat with imitation leather cover and safety belt, canopy complies with FOPS-, TOPS- and ROPS-regulations

Hydraulic

- Summation regulation
- Hydraulic oil cooler
- Hydraulic pilot control via joystick
- Valve control according to ISO, DIN, SAE, PCSA and EURO
- Park brake turn motor
- Auxiliary hydraulic connection for two directions of motion, mounted on dipperstick (1150 mm)
- Dual travel speed
- Hydraulically dampened drive pedals and levers

Neuson Baumaschinen GmbH

Haidfeldstraße 37
A-4060 Linz-Leonding

Tel. +43 (0)732 90 590-0
Fax +43 (0)732 90 590-200

e-Mail verkauf@neuson.com
www.neusonkramer.com

Kramer-Werke GmbH
Nußdorfer Straße 50
D-88662 Überlingen

Tel. +49 (0)7551 802-0
Fax +49 (0)7551 802-260

e-Mail info@kramer.de
www.neusonkramer.com

Neuson Ltd.
Crown Business Park
Dukestown, Tredegar
Gwent. NP22 4EF
United Kingdom

Tel. +44 (0)1495 72 30 83
Fax +44 (0)1495 71 39 41

e-Mail uksales@neuson.com
www.neusonkramer.com

Options

2503

Cabin

Standard cab (safety cabin, cabin heating, split front window, top swings back, bottom lifts out, windscreen wiper and washing system, 1 cabin door, covered cab interior, the cabin complies with FOPS-, TOPS- and ROPS-regulations)

Canopy with back window

Radio (Radio set incl. aerial and speakers)

Rain roof

Hydraulic

Biological oil Panolin

BP-Biohyd SE46

Flat faced couplers

Proportional control (for auxiliary hydraulic)

Overload valve for auxiliary hydraulic

Overload system Germany (Load holding valve boom)

Overload system France (Load holding valve boom and dipperstick)

Additional piping for grapple

Painting

Special paint 1 RAL (Colour for red parts only)

Special paint 1 no RAL (Colour for red parts only)

Special paint cabin RAL (RAL colours only)

Miscellaneous

Cab lighting front

Anti theft device

Flashing beacon

Long dipperstick (+200 mm)

Security 24 (1500 h) (Warranty extension to 24 months or 1500 operation hours)

Security 24 (2000 h) (Warranty extension to 24 months or 2000 operation hours)

Steel track 250 mm

Packages

Mirror package (Exterior mirror right and left)



neuson®

Subject to modifications without prior notice.
We reserve the right to change the specifications without prior notice.
Along the explicit contractual agreement is decisive.
12/05 ArtNr. 1000126375