



## Engine

Make/Type Model	Yanmar 4TNV88 water cooled 4 cylinder diesel engine
max. engine output	35,4 kW (48,1 HP)
Performance to ISO	23,7 kW (32,2 HP)
Engine displacement	2189 cm <sup>3</sup>
Travel speed	2000 min <sup>-1</sup>
Battery	12V/71 Ah
Fuel tank capacity	52 l



## Hydraulic system

Pump	Double variable capacity pump + gear pump
Pump capacity	44,5 + 44,5 + 25,1 l/min
Operating pressure for working and driving hydraulics	240 bar
Operating pressure for slewing gear	200 bar
Hydraulic oil cooler	standard
Hydraulic tank capacity	50 l



## Undercarriage and slewing system

Travel speed - dual	2,8 km/h and 5,5 km/h
Gradeability	30°/58%
Crawler width	300 mm
N° track rollers per side	4
Ground clearance	280 mm
Ground pressure	Standard: 0,33 kg/cm <sup>2</sup> Vario: 0,35 kg/cm <sup>2</sup>
Superstructure slewing speed	9,2 min <sup>-1</sup>



## Dozer Blade

Width	1620 mm
Height	370 mm
max. lift above ground	410 mm
max. lift below ground	480 mm



## Lifting power index

A \ B	max.		4,5 m		3,5 m		2,5 m		1,5 m	
	along	across	along	across	along	across	along	across	along	across
3,0 m	800*	545	-	-	745*	685	-	-	-	-
2,0 m	840*	480	-	-	870*	660	1110*	1105	-	-
1,0 m	890*	415	900*	-	1100*	620	1795*	1000	-	-
0,0 m	955*	420	955*	-	1300*	595	2130*	930	-	-
-1,0 m	1045*	475	-	-	1310*	590	2100*	950	4200*	2295
-2,0 m	1150*	675	-	-	-	-	1700*	975	3300*	2345

A = projection from turnstile centre, B = load fixing height from ground level  
 \*The lifting power is hydraulically limited.  
 The data (kg) refer to the machine without digging equipment and are in compliance with ISO 10567.  
 Overall length with dozer blade supported.  
 Neither 75% of the static tilting load nor 87% of the hydraulic lifting power are exceeded.



## Noise level

Noise level (L <sub>WA</sub> ) (to 2000/14/EG)	95 dB(A)
Noise level (L <sub>PA</sub> ) (to ISO 6394)	74 dB(A)



## General specifications

Standard

Vario

<b>Transport weight</b>			
	Cab	3500 kg	3775 kg
	Canopy	3405 kg	3680 kg
<b>Dimensions</b>			
a	— Height	2405 mm	2508 mm
b	— Width	1620 mm	1620 mm
	Transport length (boom down)	5170 mm	5170 mm
d	— max. digging depth	3230 mm	3127 mm
d*	— max. digging depth (long dipperstick)	3530 mm	3427 mm
e	— max. vertical digging depth	2220 mm	2117 mm
e*	— max. vertical digging depth (long dipperstick)	2500 mm	2396 mm
f	— max. digging height	4910 mm	5013 mm
f*	— max. digging height (long dipperstick)	5100 mm	5211 mm
g	— max. dumping height	3620 mm	3723 mm
g*	— max. dumping height (long dipperstick)	3810 mm	3923 mm
h	— max. digging radius	5270 mm	5100/5440** mm
h*	— max. digging radius (long dipperstick)	5546 mm	5296/5796** mm
j	— max. reach on the ground	5175 mm	5005/5345** mm
j*	— max. reach on the ground (long dipperstick)	5456 mm	5206/5706** mm
k	— Tail slewing radius	1400 mm	1400 mm
	max. lateral tail projection over crawlers	590 mm	420/760** mm
	max. boom offset to centre of bucket right side	685 mm	855** mm
	max. boom offset to centre of bucket left side	415 mm	585** mm
n	— max. lift above ground	410 mm	410 mm
o	— max. lift below ground	480 mm	480 mm
p	— Track length	2075 mm	2075 mm
q	— max. swing angle to the right	45°	45°
r	— max. swing angle to the left	80°	80°
s	— min. boom radius	1470 mm	1470 mm
t	— Crawler width	300 mm	300 mm
	max. arm crowd force	20,6 kN	20,6 kN
	max. arm crowd force (long dipperstick)	16,8 kN	16,8 kN
	max. bucket digging force	30,3 kN	30,3 kN

min/max\*\*

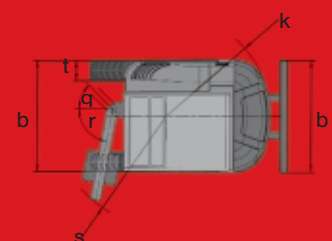
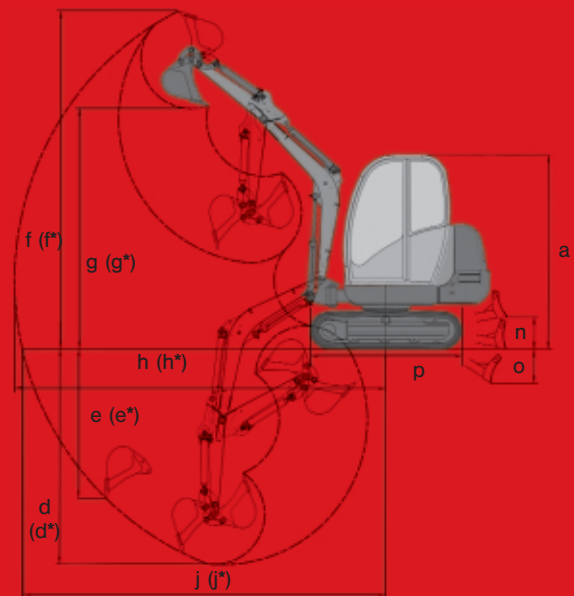

## Basic Machine

### General

- Rubber track 300 mm
- Dozer blade
- Working light mounted to the boom
- Tool kit incl. grease gun and operator manual

### Engine

- Water-cooled YANMAR diesel engine

### Cabin

- Canopy: Adjustable and resilient comfort seat with imitation leather cover and safety belt, canopy complies with FOPS-, TOPS- and ROPS-regulations

### Hydraulic

- Summation regulation
- Hydraulic oil cooler
- Hydraulic pilot control via joystick
- Valve control according to ISO, DIN, SAE, PCSA and EURO
- Park brake for drive- and turn motor
- Auxiliary hydraulic connection for two directions of motion, mounted on dipperstick (1335 mm)
- Dual travel speed
- Hydraulically dampened drive pedals and levers

#### Neuson Baumaschinen GmbH

Haidfeldstraße 37  
A-4060 Linz-Leonding

Tel. +43 (0)732 90 590-0  
Fax +43 (0)732 90 590-200

e-Mail [verkauf@neuson.com](mailto:verkauf@neuson.com)  
[www.neusonkramer.com](http://www.neusonkramer.com)

Kramer-Werke GmbH  
Nußdorfer Straße 50  
D-88662 Überlingen

Tel. +49 (0)7551 802-0  
Fax +49 (0)7551 802-260

e-Mail [info@kramer.de](mailto:info@kramer.de)  
[www.neusonkramer.com](http://www.neusonkramer.com)

Neuson Ltd.  
Crown Business Park  
Dukestown, Tredegar  
Gwent. NP22 4EF  
United Kingdom

Tel. +44 (0)1495 72 30 83  
Fax +44 (0)1495 71 39 41

e-Mail [uksales@neuson.com](mailto:uksales@neuson.com)  
[www.neusonkramer.com](http://www.neusonkramer.com)

## Options

**3503**  
STANDARD VARIO

### Cabin

Standard cab (safety cabin, cabin heating, split front window, top swings back, bottom lifts out, windscreen wiper and washing system, 1 cabin door, covered cab interior, the cabin complies with FOPS-, TOPS- and ROPS-regulations)

Canopy with back window

Radio (Radio set incl. aerial and speakers)

Rain cover

### Hydraulic

Biological oil Panolin

BP-Biohyd SE46

Flat faced couplers

Proportional control (for auxiliary hydraulic)

Overload valve for auxiliary hydraulic

Overload system Germany (Load holding valve boom)

Overload system France (Load holding valve boom and dipperstick)

Additional piping for grapple

### Painting

Special paint 1 RAL (Colour for red parts only)

Special paint 1 no RAL (Colour for red parts only)

Special paint cabin RAL (RAL colours only)

### Miscellaneous

Cab lighting front

Anti theft device

Flashing beacon

Long dipperstick (+300mm)

Security 24 (1500 h) (Warranty extension to 24 months or 1500 operation hours)

Security 24 (2000 h) (Warranty extension to 24 months or 2000 operation hours)

Steel track 300 mm

VARIO

### Packages

Mirror package (Exterior mirror right and left)



**neuson**<sup>®</sup>

Subject to modifications without prior notice.  
We reserve the right to change the specifications without prior notice.  
Alone the explicit contractual agreement is decisive.  
12/05 ArtNr. 1000126386