



## Engine

Make/Type	Yanmar 4TNV98
Model	water cooled 4 cylinder diesel engine
max. engine output	51,1 kW (69,5 HP)
Performance to ISO	42,5 kW (57,8 HP)
Engine displacement	3318 cm <sup>3</sup>
Travel speed	2100 min <sup>-1</sup>
Battery	12V/88Ah
Fuel tank capacity	93 l



## Hydraulic system

Pump	Double variable capacity pump + double gear pump
Pump capacity	2 x 82,4 + 2 x 36,6 l/min
Operating pressure for working and driving hydraulics	300 bar
Operating pressure for slewing gear	245 bar
Hydraulic oil cooler	standard
Hydraulic tank capacity	99 l



## Undercarriage and slewing system

Travel speed - dual	3,2 km/h and 5,2 km/h
Gradeability	30°/58%
Crawler width	450 mm
N° track rollers per side	5
Ground clearance	380 mm
Ground pressure	0,36 kg/cm <sup>2</sup>
Superstructure slewing speed	9,2 min <sup>-1</sup>



## Dozer Blade

Width	2300 mm
Height	500 mm
max. lift above ground	450 mm
max. lift below ground	520 mm



## Lifting power index

A \ B	max.		5,0 m		4,0 m		3,0 m		2,0 m	
	along	across	along	across	along	across	along	across	along	across
5,0 m	2000*	1510	-	-	1955*	1950	-	-	-	-
4,0 m	1920*	1165	1915*	1330	2010*	1930	-	-	-	-
3,0 m	1895*	985	2020*	1300	2315*	1845	2925*	2920	-	-
2,0 m	1905*	920	2205*	1245	2750*	1730	4070*	2620	-	-
1,0 m	1930*	890	2380*	1185	3120*	1620	4770*	2400	-	-
0,0 m	1960*	910	2455*	1145	3260*	1550	4750*	2335	-	-
-1,0 m	1975*	990	2345*	1130	3135*	1530	4375*	2330	6305*	4830
-2,0 m	1940*	1180	-	-	2690*	1545	3675*	2365	5230*	4900
-3,0 m	1700*	1700*	-	-	-	-	2385*	2385*	-	-

A = projection from turnstile centre, B = load fixing height from ground level  
 \*The lifting power is hydraulically limited.  
 The data (kg) refer to the machine without digging equipment and are in compliance with ISO 10567.  
 Overall length with dozer blade supported.  
 Neither 75% of the static tilting load nor 87% of the hydraulic lifting power are exceeded.



## Geräuschemission

Noise level (L <sub>WA</sub> ) (to 2000/14/EG)	98 dB(A)
Noise level (L <sub>PA</sub> ) (to ISO 6394)	78 dB(A)



## General specifications

	Standard	Vario
Transport weight	7625 kg	8245 kg
<b>Dimensions</b>		
a — Height	2710 mm	2864 mm
b — Width	2250 mm	2250 mm
c — Transport length (boom down)	6570 mm	6570 mm
d — max. digging depth	4290 mm	4162 mm
d* — max. digging depth (long dipperstick)	4580 mm	4462 mm
e — max. vertical digging depth (long dipperstick)	3670 mm	3516 mm
e* — max. vertical digging depth (long dipperstick)	3970 mm	3814 mm
f — max. digging height	6980 mm	7128 mm
f* — max. digging height (long dipperstick)	7170 mm	7317 mm
g — max. dumping height	4840 mm	5000 mm
g* — max. dumping height (long dipperstick)	5030 mm	5190 mm
h — max. digging radius	7170 mm	6920/7420** mm
h* — max. digging radius (long dipperstick)	7440 mm	7190/7690** mm
i — max. reach on the ground	7020 mm	6770/7270** mm
i* — max. reach on the ground (long dipperstick)	7300 mm	7050/7550** mm
max. lateral tail projection over crawlers		
k — Tail slewing radius	400 mm	150/650** mm
l — max. boom offset to centre of bucket right side	1550 mm	1550 mm
m — max. boom offset to centre of bucket left side	720 mm	970** mm
n — max. lift above ground	550 mm	800** mm
o — max. lift below ground	450 mm	450 mm
p — Track length	520 mm	520 mm
q — max. swing angle to the right	2830 mm	2830 mm
r — max. swing angle to the left	63 °	63 °
	67 °	67 °
max. arm crowd force		
	38,7 kN	38,7 kN
max. arm crowd force (long dipperstick)		
	35,1 kN	35,1 kN
max. bucket digging force		
	52,3 kN	52,3 kN

min/max\*\*

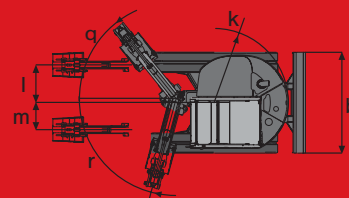
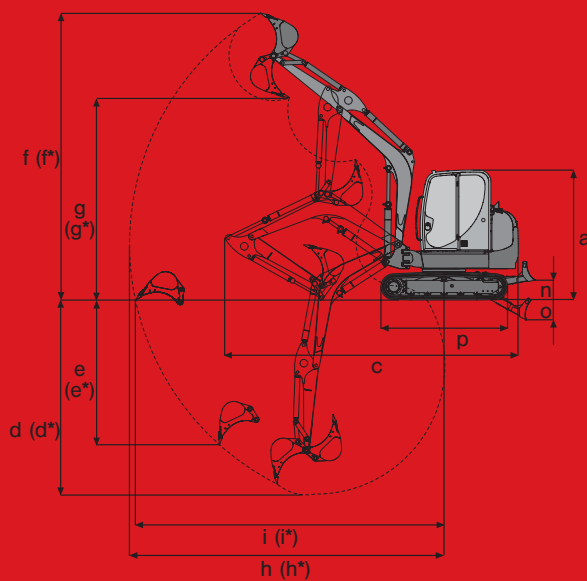

## Basic Machine

### General

- Rubber track 450 mm
- Dozer blade
- Working light mounted to the boom
- Tool kit incl. grease gun and operator manual

### Engine

- Water-cooled YANMAR diesel engine

### Cabin

- Safety glass cabin: Tilttable cabin, cabin heating, side sliding window, top swings back, windscreen wiper and washing system, covered cab interior, cabin complies with FOPS and TOPS regulations.
- Cabling for radio incl. aerial and speakers
- Cabling for cab lighting and flashing beacon

### Hydraulic

- Summation regulation
- Hydraulic oil cooler
- Hydraulic pilot control via joystick
- Valve control according to ISO, DIN, SAE, PCSA and EURO
- Auxiliary hydraulic connection for two directions of motion, mounted on dipperstick (1850 mm)
- Auto2-Speed transmission, dual travel speed operated automatically, 2<sup>nd</sup> gear manually locked
- Increased, depressurized return line (for several attachments)

**Neuson Baumaschinen GmbH**  
Haidfeldstraße 37  
A-4060 Linz-Leonding  
Tel. +43 (0)732 90 590-0  
Fax +43 (0)732 90 590-200  
e-Mail [verkauf@neuson.com](mailto:verkauf@neuson.com)  
[www.neusonkramer.com](http://www.neusonkramer.com)

**Kramer-Werke GmbH**  
Nußdorfer Straße 50  
D-88662 Überlingen  
Tel. +49 (0)7551 802-0  
Fax +49 (0)7551 802-260  
e-Mail [info@kramer.de](mailto:info@kramer.de)  
[www.neusonkramer.com](http://www.neusonkramer.com)

**Neuson Ltd.**  
Crown Business Park  
Dukestown, Tredegar  
Gwent. NP22 4EF  
United Kingdom  
Tel. +44 (0)1495 72 30 83  
Fax +44 (0)1495 71 39 41  
e-Mail [uksales@neuson.com](mailto:uksales@neuson.com)  
[www.neusonkramer.com](http://www.neusonkramer.com)

## Options

# 8003

### Cabin

- Air conditioning plant
- Air cushioned seat
- Radio

### Hydraulic

- 3rd control circuit (with proportional control)
- Biological oil Panolin
- BP-Biohyd SE46
- Flat faced couplers
- Proportional control (for auxiliary hydraulic)
- Overload valve for auxiliary hydraulic
- Overload system Germany (Load holding valve boom)
- Overload system France (Load holding valve boom and dipperstick)
- Additional piping for grabble

### Painting

- Special paint 1 RAL (Colour for red parts only)
- Special paint 1 no RAL (Colour for red parts only)
- Special paint cabin RAL (RAL colours only)

### Miscellaneous

- Cab lighting front
- Cab lighting front and rear
- Anti theft device
- Electrical refuelling pump
- Flashing beacon
- Counter weight
- Idle speed automatic operation
- Long dipperstick (+ 300 mm)
- Security 24 (1500 h) (Warranty extension to 24 months or 1500 operation hours)
- Security 24 (2000 h) (Warranty extension to 24 months or 2000 operation hours)
- Steel track 450 mm
- Vario (Cannot be combined with triple boom)
- Triple boom
- Central lubrication system

### Packages

- Comfort package (Air conditioning plant, idle speed automatic oper. radio, mirror package, cab lighting front and rear)
- Mirror package (Exterior mirror right and left)



# neuson®

Subject to modifications without prior notice.  
We reserve the right to change the specifications without prior notice.  
Alone the explicit contractual agreement is decisive.  
01/06 ArtNr. 1000126419