

Skid Steer Loader 501s

Operating data

| | |
|----------------------------|--------------------------|
| Operating weight* | 1810 kg |
| Payload | 510 kg |
| Tilting load | 1020 kg |
| Bucket volume heaped/level | 0,21/0,26 m ³ |

Engine

| | |
|--------------------|---------------------------------------|
| Make/type | Yanmar 3TNV88 |
| Model | water-cooled 3-cylinder diesel engine |
| Net engine output | 27 kW (36 PS) |
| Displacement | 1642 cm ³ |
| Operating speed | 3000 min ⁻¹ |
| Battery | 12 V/71 Ah |
| Fuel tank capacity | 45 litres |

Hydraulic system

| | |
|--|--------------------------|
| Pump | gear pump |
| Operating pressure of working hydraulics | 185 bar |
| Hydraulic capacity of working hydraulics | 42 l/min |
| Hydraulic oil cooler | standard combined cooler |
| Volume of hydraulic tank | 45 litres |

Drive

| | |
|----------------|--|
| Pump | axial piston variable displacement pump |
| Drive Speed | 10,5 km/h |
| Standard tyres | 27 x 8,5 - 15 |
| Drive concept | Quattrostatic® = 4 separate drive motor/gear units |
| Brake | hydr. parking brake |

Dimensions

| | | |
|---|--|--------------|
| a | Maximum height | 3475 mm |
| b | Height up to bucket pivot pin | 2700 mm |
| c | Cabin height | 1930 mm |
| d | Ground clearance | 225 mm |
| e | Tail projection (over rear axle) | 898 mm |
| f | Wheelbase | 885 mm |
| g | Overall length without attachment | 2263 mm |
| h | Overall length with standard bucket | 2860 mm |
| i | Maximum vehicle length | 3258 mm |
| k | Bucket height in top position | 2522 mm |
| l | Maximum dumping height | 2122 mm |
| m | Reach | 424 mm |
| n | Maximum reach (with boom in horizontal position) | 1136 mm |
| o | Dump-in angle | 30 ° |
| p | Dump-out angle | 40 ° |
| q | Dump-in angle | 105 ° |
| r | Gradient of slope | 29 ° |
| s | Width of vehicle (with standard tyres 27 x 8,5 - 15) | 1230 mm |
| t | Bucket width | 1270/1370 mm |
| u | Turning radius - tail | 1381 mm |
| v | Turning radius - front | 1656 mm |

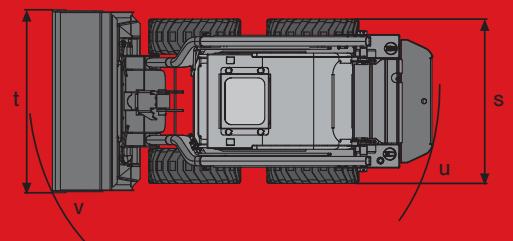
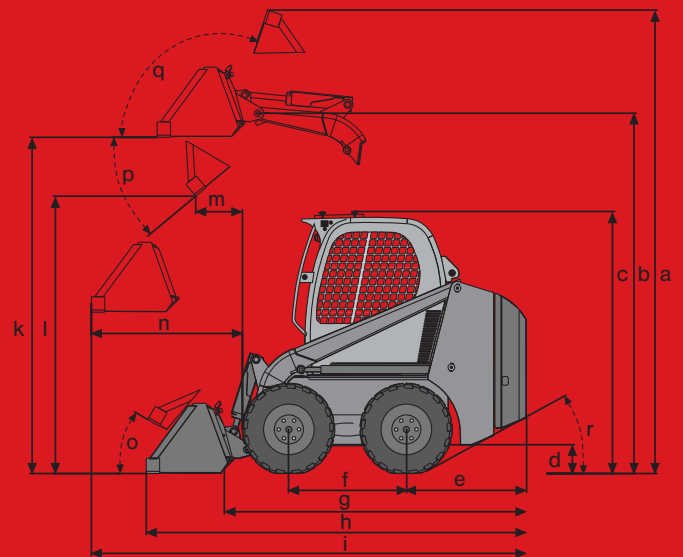

Standard equipment

Skid Steer Loader 501 s

Engine

Water-cooled YANMAR diesel engine, 3-cylinder, EPA 2

Cabin

ROPS/FOPS level 1, with 12 V power outlet, internal lighting and cargo net, lockable document box

Dashboard with numerous instruments

Adjustable seat

Retractable seat belt

Safety bar

Loading lugs

Lexan protection roof

Hydraulic system

Float position of boom

Hydraulic parking brake

Front-side auxiliary hydraulics

Combined cooler

Travelling mechanism

Quattrostatic®: This means 4 separate heavy-duty drive motors connected to the wheels via step-down gear

Advantages

- Chainless Drive
- Maximum ground clearance due to elimination of chain boxes
- Maintenance-free drive
- Low centre of gravity, gives increased stability
- New & part worn tyres can be mounted on the same side

Miscellaneous

Universal quick-hitch system

Compatible wheel hub dimensions

Options

501_s

Airboss® tyres

Rear worklights

BP-Biohyd SE 46

Bio oil Panolin

Theft protection

Rotary beacon

Single-point lifting kit

FOPS roof level 2

Accelerator pedal

Inside rearview mirror

Comfort seat

Reverse alarm

Mirror package (mirrors left and right)

Security 24 (1500h)

Security 24 (2000h)

Bucket self-levelling (selectable for upward movement)

Narrow tyres (width with narrow shovel 1190 mm)

Side window

Special paint RAL (colour only for red parts)

Special paint non RAL (colour only for red parts)

Road homologation kit

Wide range of attachments

Vandalism protection

Hydraulic pilot controls (hydraulically pilot-operated travelling mechanism and working hydraulics with load limit sensing control of the tandem pump optional ISO-pattern or twin lever controls (H-pattern hand controls))

Neuson Baumaschinen GmbH

Haidfeldstraße 37
A-4060 Linz-Leonding

Tel. +43 (0)732 90 590-0
Fax +43 (0)732 90 590-200

e-Mail verkauf@neuson.com
www.neusonkramer.com

Kramer-Werke GmbH
Nußdorfer Straße 50
D-88662 Überlingen

Tel. +49(0)7551 802-0
Fax +49(0)7551 802-260

e-Mail info@kramer.de
www.neusonkramer.com

Neuson Ltd.
Crown Business Park
Dukestown, Tredegar
Gwent. NP22 4EF
United Kingdom

Tel. +44 (0) 1495 72 30 83
Fax +44 (0) 1495 71 39 41

e-Mail uksales@neuson.com
www.neusonkramer.com

