

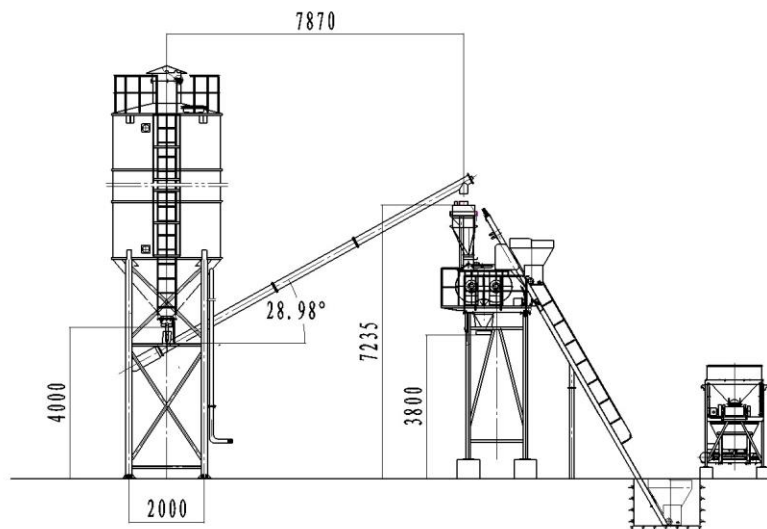

HZS25/35

Concrete Batching Plant



HZS25/35

Concrete Batching Plant



Built For Efficiency

- Specially designed for on-site projects, minimizes the installation period and easy to be moved from one site to another.
- Unlike those ready-mix plants, the on-site type requires less space to fit the other machines used and makes sure the period commitment available.
- Twin shaft compulsory mixer and all materials are being measured by sensors ensure highest quality concrete.

Easy to Maintain

- Convenient placement of key maintenance points. Parts, service and attachments you can count on.

Always Reliable

- World class components used for key systems.
- 4 layers of seal prevent leaks. Blade, lining board and mixing arms made of highly wear resistant chromium alloy.
- Fine and coarse scales are available to ensure the aggregate measuring accuracy.

Operator Safety and Comfort

- On ground design to avoid water collection under the aggregate batcher in rain seasons.
- Operator oriented information display allows the operator to timely monitor the whole production process .
- The mixing process can be controlled both automatically and manually, this allows the operator to choose the manual mode temporarily if any trouble occurs.

Technical Data

Model	HZS25	HZS35
Productivity (m ³ /h)	25	35
Cycle period (s)	60	60
Mixer	JS500	JS750
Mixer Capacity (L)	500	750
Silos (t)	1 × 50	1 × 50
Aggregate Hoppers (m ³)	2 × 3	3 × 3.2
Concrete Discharge Height (m)	3.8	3.8
Total Power Consumption (kW)	60	85
Aggregate Measuring Accuracy	± 2%	± 2%
Cement Measuring Accuracy	± 1%	± 1%
Fly-Ash Measuring Accuracy	± 1%	± 1%
Water Measuring Accuracy	± 1%	± 1%
Additive Measuring Accuracy	± 1%	± 1%

Guangxi Liugong Machinery Co., Ltd.

No. 1 Liutai Road, Liuzhou, Guangxi 545007, PR China

T: +86 772 388 6124 E: overseas@liugong.com

www.liugong.com

03/2013 Designed by LiuGong

Specifications and designs are subject to change without notice. Machines shown may include optional equipment.